

# POWER-LIFT

CI/SfB

(66.1) X

***A quality engineered product offering a choice from a wide standard range or purpose built designs.***



## **HYDRAULIC LIFT TABLES FOR ALL YOUR NEEDS**

**VEHICLE LOADING ● PROCESS PLANT ● DISABLED ACCESS  
MECHANICAL AND MANUAL HANDLING**

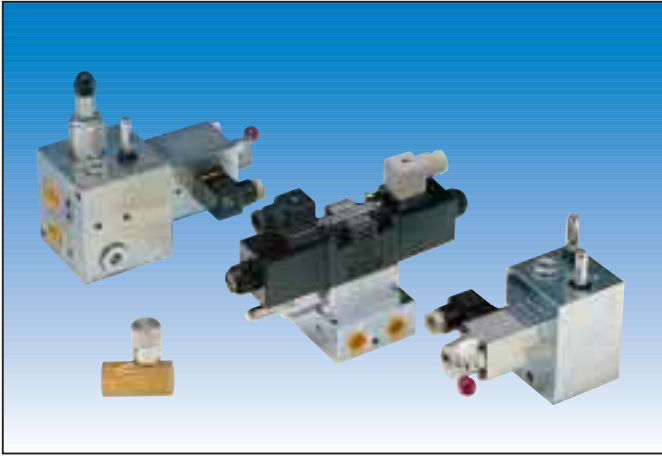

A selection from the wide range of the control valves available. For example, pilot operated check valves, circulation by-pass valves, stop valves and a standard manual lowering override unit. Our lifts are in everyday use worldwide. Our technicians have considerable experience in providing hydraulic and electrical control systems for use in the most demanding environments.



The wide range of long life motors, pumps and valves we offer make it possible for us to meet our clients' requirements for speed and frequency of operation. Dual speed and soft start are options.

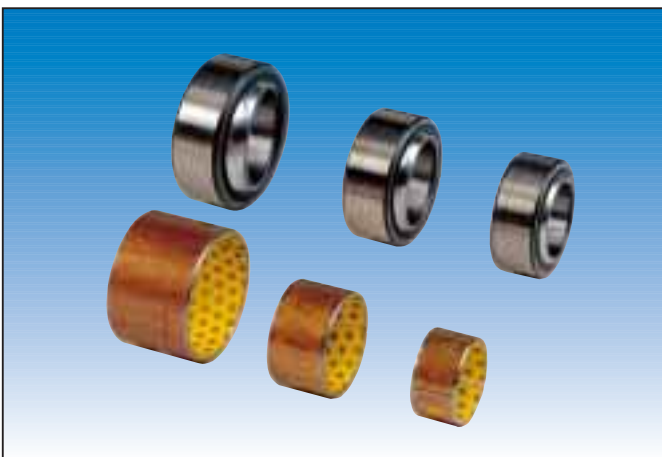

**4.** Pre-lubricated, replaceable type bearing bushes are standard features. Fe510 steel or equivalent is used for the precision ground axles and cylinder bolts. For heavy duty work we recommend chrome plating heavy wear parts, including grease points or grease free spherical plain bearings with seals. For lifts working multi-shifts, in foundries or under other exceptional conditions we usually recommend sealed, spherical bearings all over. Our technicians are always willing to discuss solutions with our clients.



**8.** Our own, high quality cylinder tubes are made from Fe510 steel with the internal bore honed and polished to an exceptionally smooth surface of  $R_a < 0.4\mu\text{m}$ . All cylinder tubes are subjected to individual inspection by quality control prior to use. The piston rods are made to the same high standards as the cylinders and are hard chrome plated to a thickness of  $> 25\mu\text{m}$ . Hose break rupture valves are built into the bottom of the cylinders. To reduce corrosion, loss of oil, and contamination, a drainhose is connected from the cylinder back to the tank (except S.. types). The safety factor by cylinder stress calculations is 1,8. Pressure hoses comply to main european standards.



The power-pack shown above is typical of those marked s1 in the standard range. The unit is mounted onto a driptray off the floor. It is connected by 1 metre of hydraulic hose to the lift.

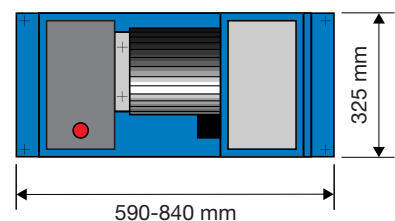
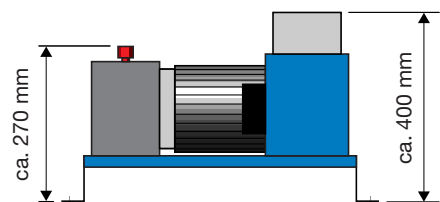



# SINGLE SCISSOR

...more than 40 different types!

- Stroke approx. 0.62 x platform length
- Upto 15 tonnes payload
- Multi purpose use
- Strong, reliable design



5 tonnes U.D.L. 4000 mm long x 1500 mm wide, 2,500 mm stroke.



4 tonnes U.D.L. For feeding steel sheet in machine shop, VW works.

**1.** Flat or chequer plate deck top. The top roll over edges are square (not radius) for greater strength, smoother load transfer and flush mounting of handrail, conveyors etc..

**2.** A perimeter safety trip frame is fitted to the undersides of the platform to prevent further lowering should an obstruction be encountered. For added safety, operator reset is standard.

**3.** The scissor arms for lift tables upto 3 metres in length are usually profiled, solid steel. For larger lifts, steel hollow section (fully capped and sealed to resist internal corrosion) is used to provide greater stability. A substantial torsion tube is fitted between the armsets to help ensure good synchronisation and stability even when eccentrically loaded.

**5.** The 1,400 rpm power packs are selected for their exceptional reliability and low noise (<70dBA). A built in high pressure filter helps protect the lowering valve from malfunction. The lowering speed is adjustable on site and is controlled by a pressure compensating valve. Mains supply 400V, 3 phase, 50Hz; control circuits 24V, 50 Hz. except for types marked \*(230V, 1 phase, 50Hz). Each lift is protected to IP54 and is ready to use when connected to a mains supply and suitably installed. The control station is on 3 metres of flexible cable complete with Emergency Stop and deadman (constant pressure) UP and DOWN push buttons.

**6.** Steel swivel stops or posts are provided to mechanically support the lift in a raised or semi-raised position to allow access for maintenance purposes.

**7.** The steel arm roller bearings are replaceable.

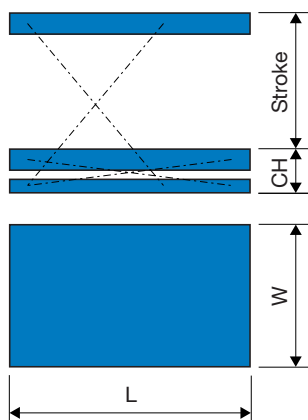

Type	L x W mm	Stroke mm	CH mm	Load kg	Time sec	Motor kW	Weight kg
EL5-80	1000x700	600	190	500	7	0.75	140
EL10-80	1000x700	600	190	1000	14	0.75	160
EL5-100	1250x800	800	190	500	10	0.75	180
EL10-100	1250x800	800	190	1000	16	0.75	210
EL20-100	1250x800	780	220	2000	32	0.75	270
EL30-95	1250x800	700	240	3000	18	1.5	280
EL10-125	1600x800	1000	240	1000	24	0.75	320
EL20-125	1600x800	1000	240	2000	48	0.75	350
EL30-125	1600x1000	970	280	3000	48	0.75	450
EL20-160	2000x1000	1300	280	2000	30	1.5	700
EL30-165	2000x1250	1250	350	3000	45	1.5	900
EL10-195	2500x1000	1600	280	1000	30	1.5	700
EL20-195	2500x1250	1600	360	2000	45	1.5	900
EL30-195	2500x1250	1570	380	3000	55	1.5	1000

# DOUBLE HORIZONTAL SCISSOR

...over 40 standard models

- Upto 30 tonnes payload
- Stroke approx. 0.32 x platform length
- Suitable for long loads
- Mechanically synchronised



To reduce workforce back injuries this 4 tonnes capacity double horizontal scissor lift table is used to raise the load to an ergonomically correct height for onward handling.



This 6 tonne unit (type EH60-165ADCN) is used for feeding long, heavy items into an automated process line. It has greasable bearing bushes and chrome plated main axle and cylinder bolts.



A 22.5 Tonnes capacity lift for raising large items onto a production line.

Type	L x W mm	Stroke mm	CH mm	Load kg	Time sec	Motor kW	Weight kg
EHL10-80	2000x800	600	190	1000	14	0.75	250
EHL20-80	2000x800	600	190	2000	28	0.75	300
EHL10-100	2500x800	800	190	1000	20	0.75	380
EHL20-100	2500x1000	800	190	2000	32	0.75	420
EHL40-100	2500x1000	780	220	4000	30	1.5	580
EHL20-125	3200x1000	1000	240	2000	48	0.75	650
EHL40-125	3200x1000	1000	240	4000	48	1.5	720
EHL60-125	3200x1000	970	280	6000	48	1.5	800
EHL20-155	4000x1000	1300	260	2000	30	1.5	1000
EHL40-160	4000x1250	1300	320	4000	30	3.0	1300
EHL60-165	4000x1250	1250	390	6000	45	3.0	1600
EHL20-165	5000x1500	1600	320	2000	30	3.0	1700
EHL40-195	5000x1500	1600	400	4000	45	3.0	2000
EHL60-195	5000x1500	1570	420	6000	55	3.0	2300

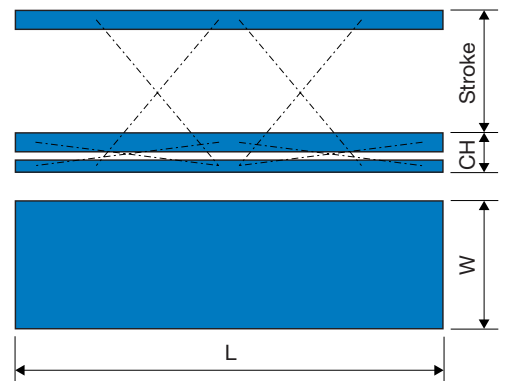

# DOUBLE VERTICAL SCISSOR

...Over 40 standard models

- Upto 4 tonnes payload
- Stroke approx. 1.2 x platform length
- Suitable for high rise lifts



A 2 tonnes capacity, double vertical scissor lift with 1 metre remote power pack for easy maintenance access. The two cylinders give increased stability.



A 1 tonne capacity, hot dipped galvanised scissor lift in a food packing hall. Note how the base frame is raised to allow for relocation by fork truck.



A 3 tonnes capacity, 3,000mm stroke lift used for stacking on a production line. Note the twin arm roller bearings.

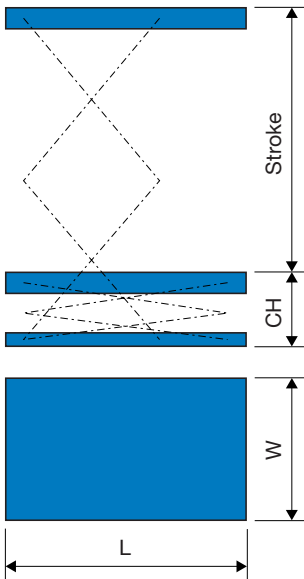

Type	L x W mm	Stroke mm	CH mm	Load kg	Time sec	Motor kW	Weight kg
EVL3-92	600x500	700	220	300	12	0.75s1	100
EVL5-104	700x500	800	230	500	14	0.75s1	130
EVL5-124	800x700	1000	240	500	20	0.75s1	140
EVL5-140	1000x800	1150	250	500	14	0.75s1	200
EVL10-140	1000x800	1150	250	1000	28	0.75s1	230
EVL5-188	1250x800	1550	330	500	16	0.75	270
EVL10-188	1250x800	1550	330	1000	32	0.75	350
EVL10-220	1500x1000	1800	400	1000	48	0.75	480
EVL20-220	1500x1000	1700	420	2000	40	1.5	550
EVL5-242	1600x800	2000	420	500	24	0.75	400
EVL10-242	1600x800	2000	420	1000	48	0.75	500
EVL10-280	2000x1000	2400	420	1000	60	0.75	800
EVL20-290	2000x1000	2400	520	2000	54	1.5	1000

# STAINLESS STEEL LIFT TABLES

...also Hot Dipped Galvanised

- For hostile environments, inc. chlorine
- Totally enclosed box section
- Bead blasted surface
- Recommended for food industry use



A specially built 1,200Kg capacity lift table with powered roller track. It is made for the food industry from EN 1.4301 stainless steel (normal stainless steel 18/8).



An E12-125YSS special built lift table made from EN 1.4301 stainless steel with specially painted cylinders and chrome plated stainless steel rods. The lift control is by foot switch.



A number of 1,200Kg capacity lift tables being used in a process hall. The environment is extremely aggressive due to concentrated salt water sprays. The working height needs constant adjustment to prevent damage to the operators' backs as the loads are heavy and difficult to handle.

## General guide/information for stainless steel and galvanised tables.

<b>Cylinder type</b>	<ol style="list-style-type: none"> <li>1. Complete stainless steel EN 1.4301 or EN 1.4401.</li> <li>2. Standard cylinder tubes coated with corrosion resisting primer and spray coated with a 2 component acrylic resin paint finish, colour RAL 7032 grey. Piston rod of chrome plated stainless steel.</li> </ol>
<b>Fabrication</b>	<ol style="list-style-type: none"> <li>1. Completely from EN 1.4301 or EN 1.4401 stainless steel.</li> <li>2. Combination of Stainless platform and bottom frame with hot dipped galvanised armset.</li> <li>3. Hot dipped galvanised.</li> </ol>
<b>Bearings</b>	All axles and cylinder bolts of stainless steel and bearing bushes with grease points.
<b>Power pack</b>	We recommend placing the power pack and control panel in a remote location or covering with a stainless steel hood.



# LOW CLOSED LIFTS

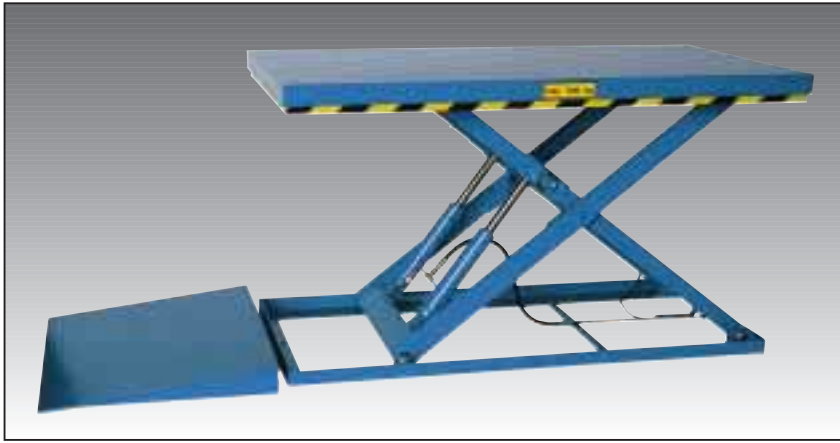

The above table is a SEL10-80 down rated to 700Kgs for an eccentric load. The ramp supplied allows for Euro-pallet loading by pallet lifter. The low closed range is also supplied as a 'U' shaped platform which allows the pallet lifter and manual pump truck forks between the scissor arms with no need for the ramp. The power pack is remote.

- For Euro-pallets
- Pit not necessary
- For light duty use

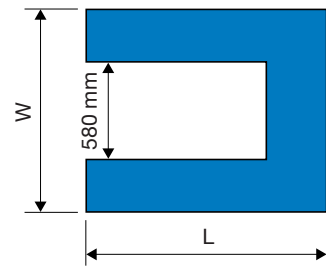
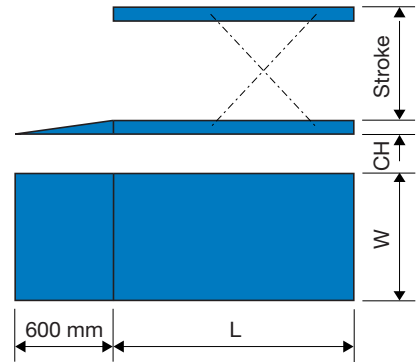

Type	L x W mm	Stroke mm	CH mm	Load kg	Time sec	Motor kW	Weight kg
SEL5-80	1400x800	700	80	500	10	0.75s3	160
SEL10-80	1400x800	700	90	1000	20	0.75s3	180
SEL20-80	1400x1000	700	90	2000	20	1.5s3	250
SUEL10-80	1400x1100	700	90	1000	20	0.75s3	200
SUEL15-80	1400x1100	700	112	1500	20	0.75s3	230

# SPECIAL TYPES



A special type of pallet lifter with powered wheels for use on rails. It has a capacity of 1,500Kgs and a vertical stroke of 600mm. It can be used as a combined lift / transporter on a production line.

Lift table type E5-80T45 with tilting platform of 45 degrees around 1 long side. Note the reinforced baseframe



A 1,000Kg Euro-pallet lifter. Vertical stroke of 800mm. A low closed height of 80mm, allows loading by a standard manual pump truck.

2 tonne lift table type EL20-160T30 with 30 degrees top frame tilt table for supporting a torpedo. It is used by the Swedish Navy and several NATO members as a simulator for the test of torpedo control systems.



# OPTIONAL FEATURES

Combinations are available

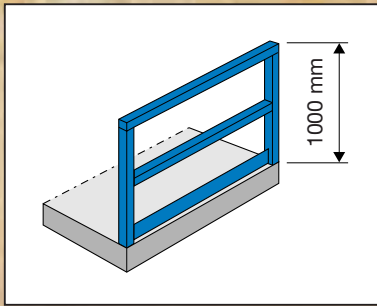

Platform mounted handrail, fixed or de-mountable. Gates can also be included.



Mobile units, choice of wheels to suit. Powered or manually moved.



Galvanised steel mesh curtain to resist ingress to undersides of lift platform.

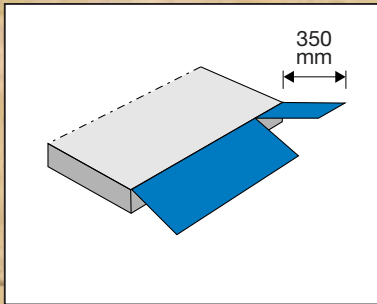

Loading flaps/bridge plates. Manually operated (with gas strut assistance) or hydraulically powered.



Gravity or powered roller track(s), ball top unit or skate wheels.

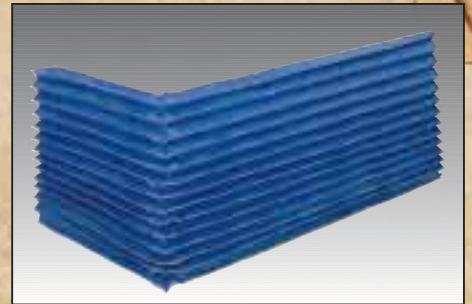

Bellows guard to provide protection. Also consider roller blind or rigid steel panels.

## Other available features include

Altering platform dimensions, height limit switches, foot operated controls, extra push button stations, turntables, auto rising wheelstops, palletised baseframe, adjustable platform support legs, lifting eye bolts, access hatch in platform, reinforced or open frame platform.

## TYPE KEY FOR HYDR. SCISSOR LIFT TABLES

<b>S</b> Low built table	Customer standard specification
<b>U</b> U-shaped platform	<b>SS</b> Stainless steel in specification
<b>2x</b> Hydraulic synchronised single scissors	<b>G</b> Hot galvanised
<b>E</b> Electro hydraulic single acting cylinders	<b>M</b> Mobile
<b>ED</b> Electro hydraulic double acting cylinders	<b>Z</b> El. system differs from standard
<b>H</b> Double horizontal scissors	<b>Y</b> Hydr. system differs from standard
<b>V</b> Double vertical scissors No sign for single scissors	<b>X</b> Scissor constr. differs from standard
<b>L</b> Integrated hydr. power pack No sign for special build power pack	<b>D</b> Main scissor plain spherical bearing
Uniformly distributed safe working load in kN (10 kN $\approx$ 1000 kg)	<b>N</b> Grease nipples at all bearing bushes
	<b>C</b> Chromium plated cyl. bolts and main axle
	<b>A</b> Any deviation from standard platform sizes
	Total platform height in cm

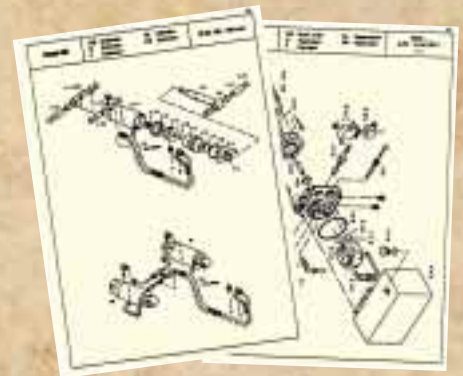

## Documentation

A comprehensive, printed owner/operator manual, complete with diagrams, exploded views and spare parts list is provided with each lift in its own individual front cover for easy identification. Special certificates can be supplied.

## Surface coating

Each lift table is fully protected with a hard wearing 2 component acrylic resin finish surface coating. Other finishes are available upon request.

Info, sales and service:

Smeyers-TU

Treff 61 / 3

B - 1853 Strombeek

www.smeyers-tu.be

Tel +32-2 461 21 09

Fax +32-2 461 21 44

info@smeyers-tu.be